

FNAME: WS3P-TP-3010

REVDATE: 0521

REVISIONS				
ZONE	REV	DESCRIPTION	DATE	APPROVED
	A	UPDATED DRY CONTACT RATINGS	5/4/21	JED

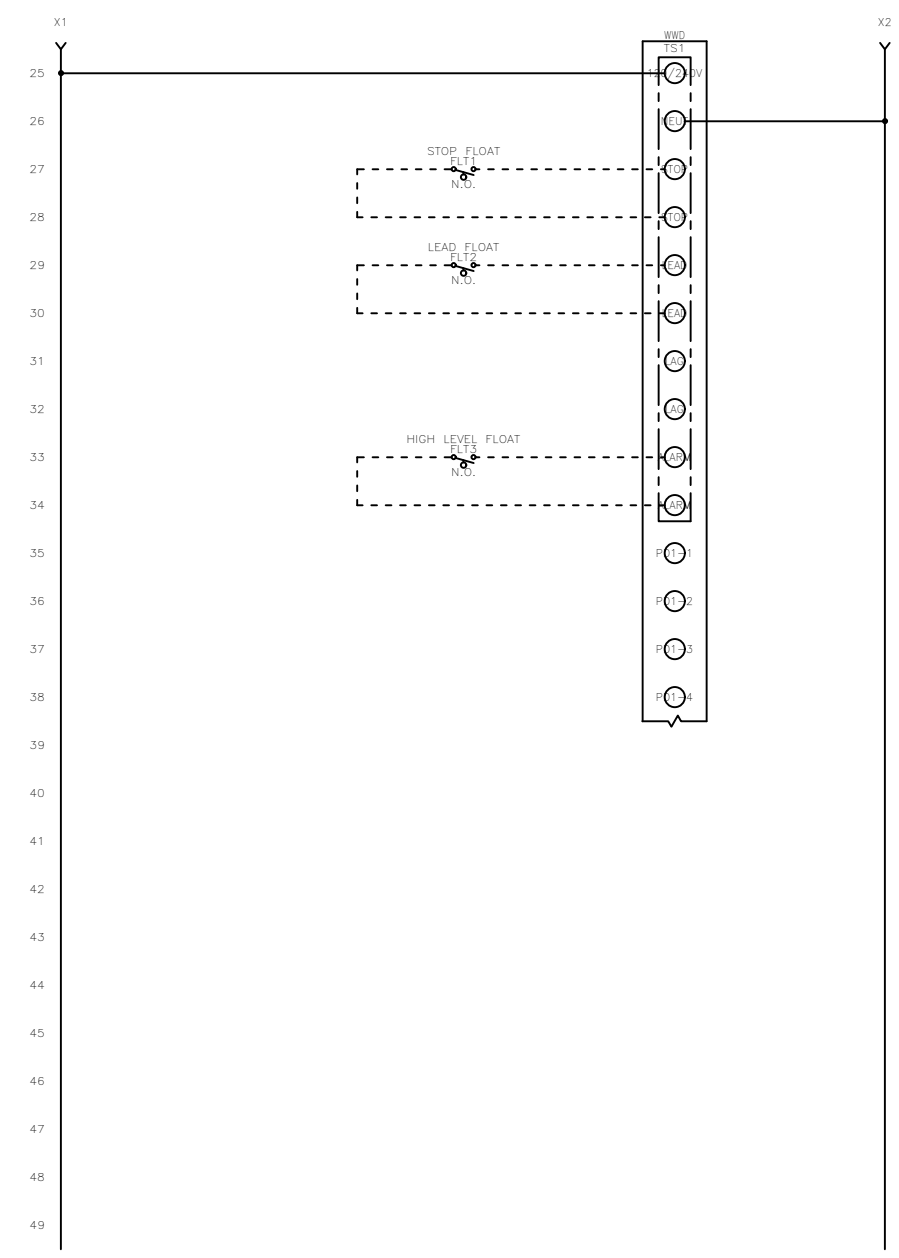
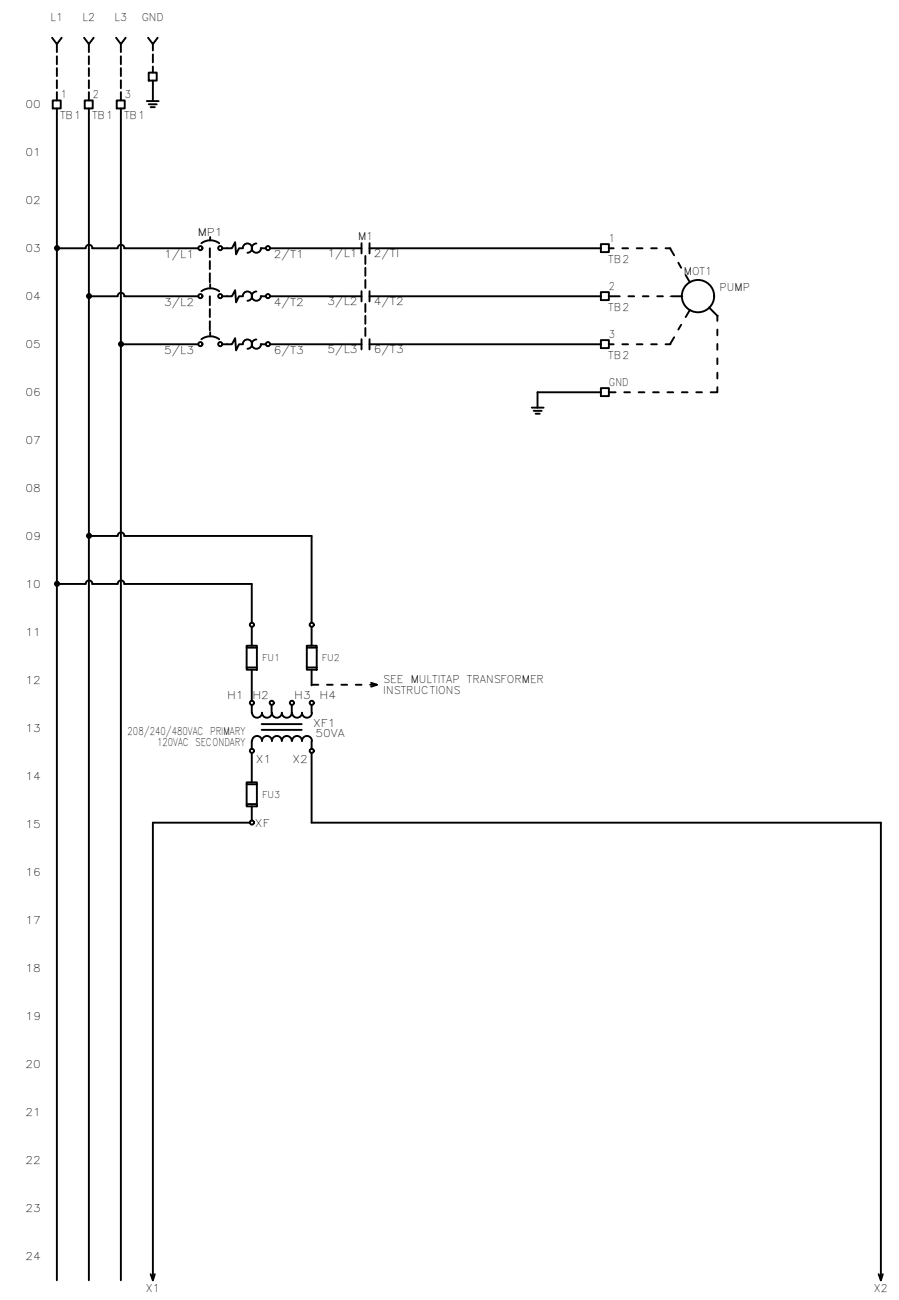

**MULTI-TAP TRANSFORMER:**  
 CONNECT FACTORY TAGGED WIRES TO APPROPRIATE TRANSFORMER VOLTAGE TAP. SEE BELOW FOR CONNECTIONS:  
 FOR 208V OPERATION, CONNECT TO FUSE INPUT HF & TO TRANSFORMER TAP H2.  
 FOR 240V OPERATION, CONNECT TO FUSE INPUT HF & TO TRANSFORMER TAP H3.  
 FOR 480V OPERATION, CONNECT TO FUSE INPUT HF & TO TRANSFORMER TAP H4.

----- DASHED LINE INDICATES FIELD WIRING.  
 USE COPPER CONDUCTORS ONLY.  
 TEMPERATURE RATING OF CONDUCTORS IS TO BE:  
 60°C (140°F) FOR UNDER 100A.  
 75°C (167°F) FOR OVER 100A.  
 BRANCH CIRCUIT PROTECTION SHALL BE PROVIDED BY THE INSTALLER: MUST BE SIZED ACCORDING TO PUMP/MOTOR MANUFACTURING SPECIFICATIONS.  
 VERIFY CORRECT OPERATION OF CONTROL PANEL AFTER INSTALLATION IS COMPLETE.

FIELD WIRING TORQUE SPECS.	
TERMINAL BLOCK UT 2,5	5 IN-LB
TERMINAL BLOCK UT 4	7 IN-LB
TERMINAL BLOCK UT 6	15 IN-LB
TERMINAL BLOCK UT 10	15 IN-LB
TERMINAL BLOCK UT 16	25 IN-LB
TERMINAL BLOCK UT 35	30 IN-LB
TS1, TS2, J2 & J3 PCB	5 IN-LB
TRANSFORMER H1F, H2F & H3F	15 IN-LB
TRANSFORMER H1, H2 & H3	10 IN-LB
DS1 VLS3P63-125 R2	45 IN-LB
DS1 LK4JU3CN 100A	36 IN-LB
DS1 LK4MU3N 200A	200 IN-LB

DRAWN BY: JED DATE: 3/4/21  
 APPROVED BY: KM DATE: 3/4/21

THIS DRAWING CONTAINS PROPRIETARY INFORMATION AND SHALL NOT BE USED OR DISCLOSED WITHOUT PRIOR WRITTEN AUTHORIZATION.



TITLE: WS3P-TP-3010 CONTROL SCHEMATIC			
SIZE: B	DWG NO.: 2216	PART NO.: WS3P-TP-3010	REV: A
SCALE: NONE		SHEET: 1 OF 2	

FNAME: WS3P-TP-3010

REVDATE: 0521

REVISIONS				
ZONE	REV	DESCRIPTION	DATE	APPROVED
	A	UPDATED DRY CONTACT RATINGS	5/4/21	JED

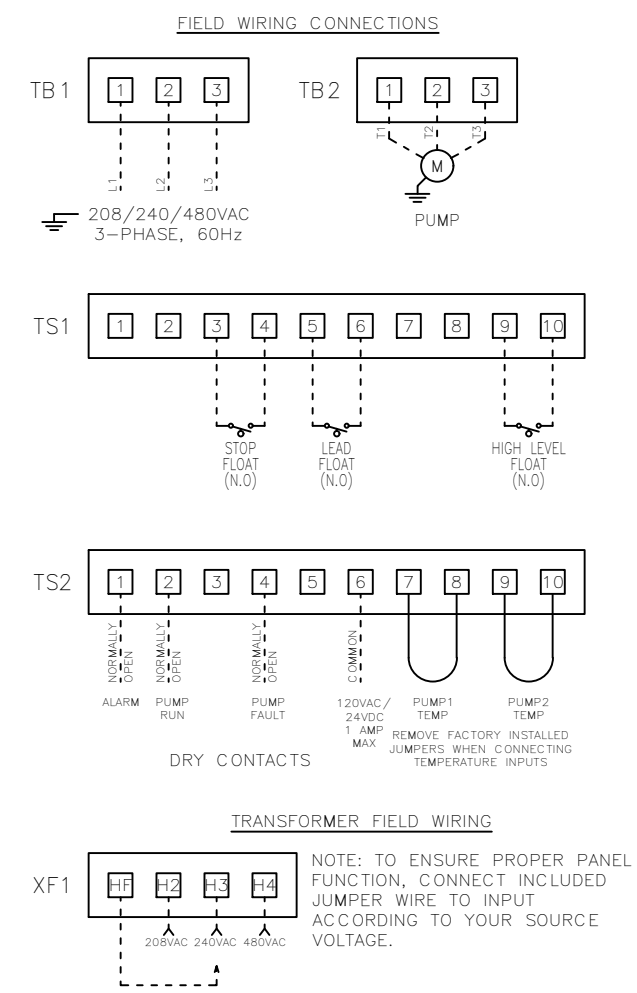
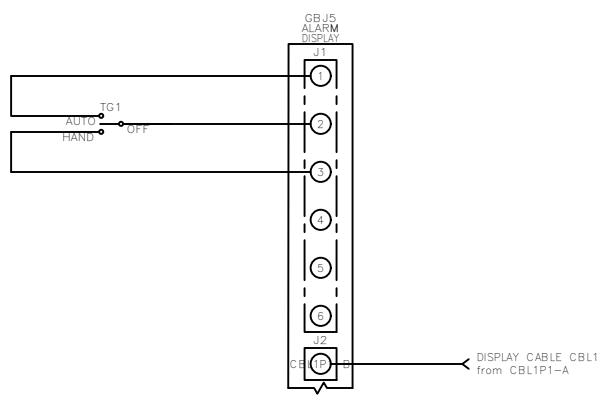
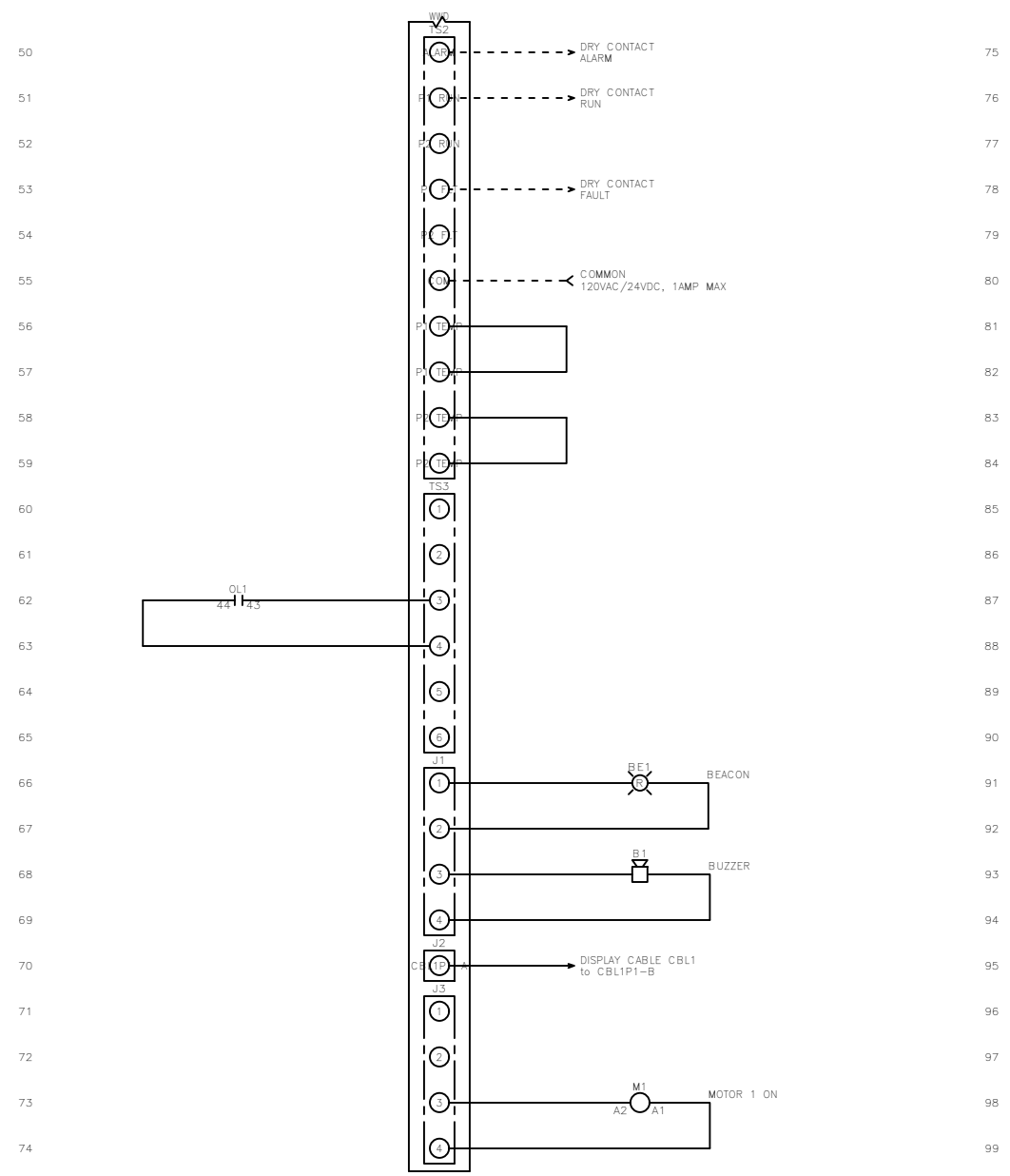

**MULTI-TAP TRANSFORMER:**

CONNECT FACTORY TAGGED WIRES TO APPROPRIATE TRANSFORMER VOLTAGE TAP. SEE BELOW FOR CONNECTIONS:

FOR 208V OPERATION, CONNECT TO FUSE INPUT HF & TO TRANSFORMER TAP H2.

FOR 240V OPERATION, CONNECT TO FUSE INPUT HF & TO TRANSFORMER TAP H3.

FOR 480V OPERATION, CONNECT TO FUSE INPUT HF & TO TRANSFORMER TAP H4.

----- DASHED LINE INDICATES FIELD WIRING.

USE COPPER CONDUCTORS ONLY.

TEMPERATURE RATING OF CONDUCTORS IS TO BE:  
60°C (140°F) FOR UNDER 100A.  
75°C (167°F) FOR OVER 100A.

BRANCH CIRCUIT PROTECTION SHALL BE PROVIDED BY THE INSTALLER: MUST BE SIZED ACCORDING TO PUMP/MOTOR MANUFACTURING SPECIFICATIONS.

VERIFY CORRECT OPERATION OF CONTROL PANEL AFTER INSTALLATION IS COMPLETE.

FIELD WIRING TORQUE SPECS.	
TERMINAL BLOCK UT 2,5	5 IN-LB
TERMINAL BLOCK UT 4	7 IN-LB
TERMINAL BLOCK UT 6	15 IN-LB
TERMINAL BLOCK UT 10	15 IN-LB
TERMINAL BLOCK UT 16	25 IN-LB
TERMINAL BLOCK UT 35	30 IN-LB
TS1, TS2, J2 & J3 PCB	5 IN-LB
TRANSFORMER H1F, H2F & H3F	15 IN-LB
TRANSFORMER H1, H2 & H3	10 IN-LB
DS1 VLS3P63-125 R2	45 IN-LB
DS1 LK4JU3CN 100A	36 IN-LB
DS1 LK4MU3N 200A	200 IN-LB

DRAWN BY: JED DATE: 3/4/21  
APPROVED BY: KM DATE: 3/4/21

THIS DRAWING CONTAINS PROPRIETARY INFORMATION AND SHALL NOT BE USED OR DISCLOSED WITHOUT PRIOR WRITTEN AUTHORIZATION.



TITLE: WS3P-TP-3010 CONTROL SCHEMATIC			
SIZE: B	DWG NO.: 2216	PART NO.: WS3P-TP-3010	REV: A
SCALE: NONE		SHEET: 2 OF 2	